

Code

Description

UPA-CTL115	Anchor UPA-TL length 115 mm
UPA-CTL145	Anchor UPA-TL length 145 mm
UPA-CTL320	Anchor UPA-TL length 320 mm

(*) Other lengths available under request.
For length $L > 600$ mm, ask us for the service load

(1) **Surface treatment:** Electroplated zinc coating
Service load: 1300 Kg

1. Other surface treatment available under request.

Accessory for retaining precast concrete elements. Mounting with NOXI profile, FER TF16-40 screw, A16 washer, Glower AG16 washer, T16 nut and expansion plug. With this system, assembly regulation is achieved in 2 of the 3 main axes.

Anchor UPA-CTL



www.noxifer.com



1

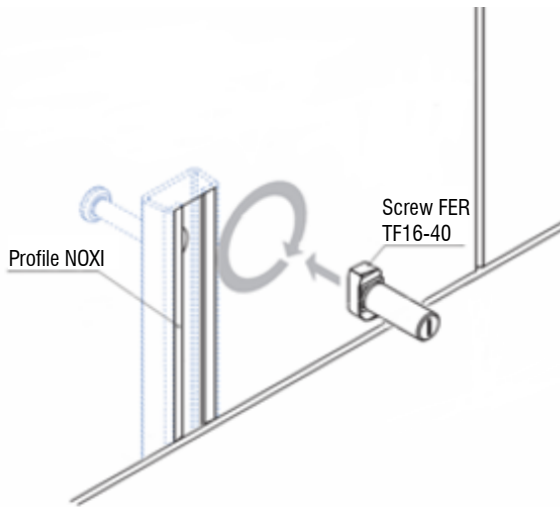

1.1.- Place the FER screw into the profile* and turn it 90 degrees.

* The profile can be: NOXI C, R or S; depending of loads.

2

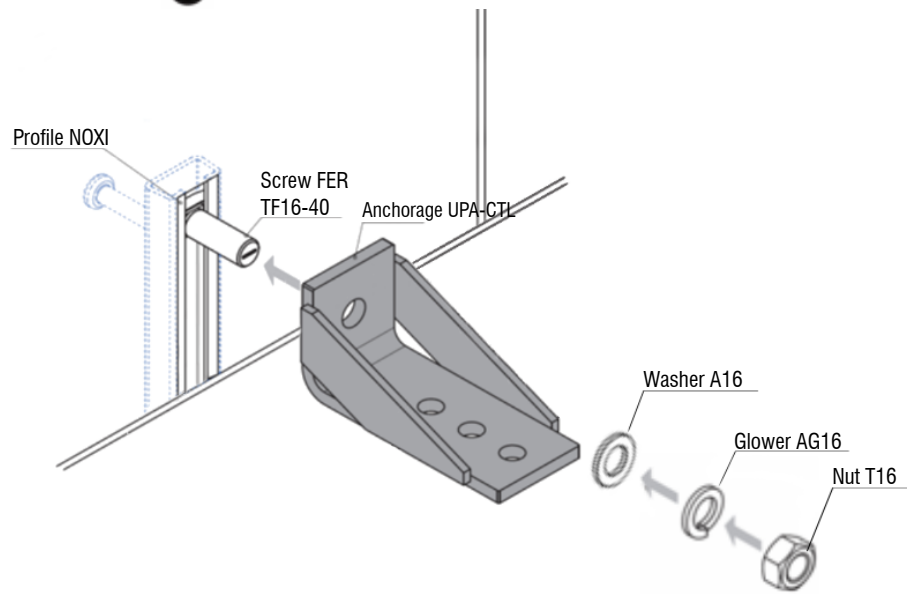

2.1.- Screw and anchor assembly through hole $\varnothing 17$.

2.2.- Fixation by washer A16, Glower washer AG16 and nut T16. The Glower washer should be completely flat.

3

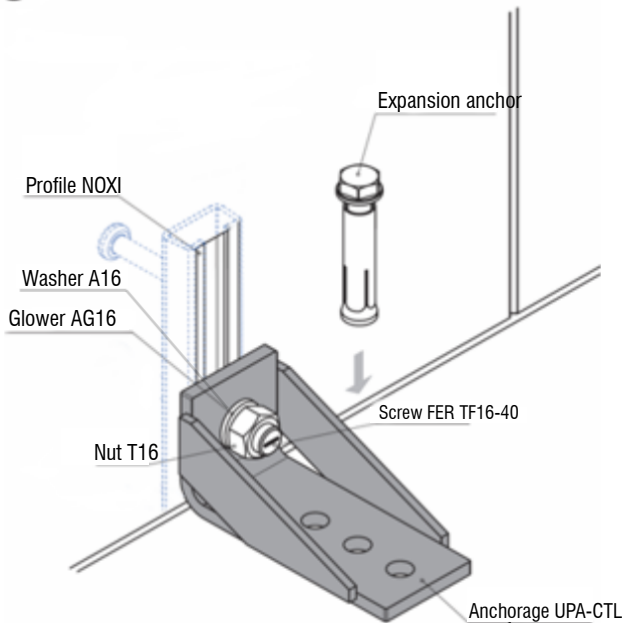

3.1 Making the hole to accommodate the expansion shell in any of the three $\varnothing 14$.

3.2.- Insert the expansion shell through the anchorage holes and the concrete.

4

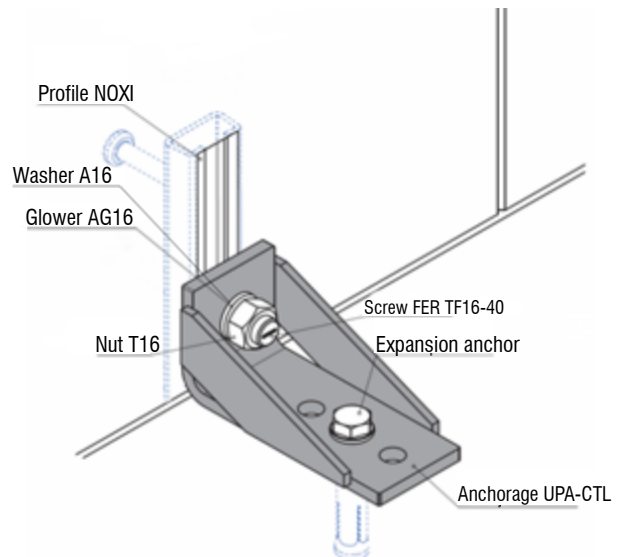

4.1.- Press the expansion shell (according to the manufacturer's instructions) to finish the assembly.

4.2.- Final check and assurance of the tightening of the nut and the installation of the fixing screw.

In order to continue the assembly sequence all the steps above described must be successfully overcome.