

Code	Description	Distance between connectors
PN200S	Profile NOXI S length 20 cm	120 mm

*Possibility of manufacture in different lengths on request.

Surface treatment	Hot-dip galvanized
Service load	1800 Kg (tension) 1800 Kg (shear)
Global Security Coefficient	2.22
Concrete	≥ HA-35

Profile to insert into concrete modules using rigid connectors.

Profile NOXI S



www.noxifer.com



1

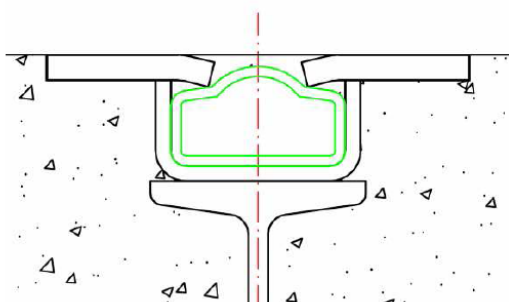

Correct

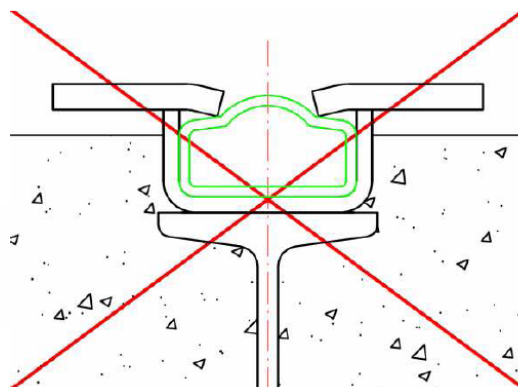

Incorrect

- 1.1.- Position the profile according to the instructions provided by the Technical Department.
- 1.2.- Leave the profile completely embedded in the concrete and flush with the upper surface.

2



- 2.1.- Remove the polystyrene protection, if desired.
(Accessories can be inserted without removing polystyrene)

To continue the assembly sequence, all the steps described must be successfully completed.